



PTFE Seals

For superior sealing performance

Contents

03 About M Seals

04 PTFE Sealing
Systems

05 Range of
Seals

07 General Material
Characteristics

08 M-FLEX

14 M-STEP /
M-GLIDE

16 M-TURN

17 M-CAP

19 M-GLIDE

20 M-WIPE

21 M-FLEX Groove
Dimension

22 Surface Finishes

23 O-Ring Inside
Dimension



About M Seals

Expert Sealing Solutions Designed for Industrial Performance.

M Seals is an international company founded in 1963 in Denmark, with offices in Sweden, the UK, Poland, Finland and China. Our many years of experience and knowledge make us a preferred sealing solutions supplier for customers worldwide.

We specialise in the design, manufacture and supply of sealing components and offer a comprehensive range of products tailored to different applications and industries. Our products range from standard seals, with thousands in stock for next day delivery, to customised solutions that meet specific requirements and special environmental conditions.

In 2007, M Seals became a part of Diploma PLC, giving us access to extensive resources and support. This affiliation allows us to offer expert advice, innovative solutions, and high-quality service, benefiting from shared knowledge and best practices within the group. This ensures we stay at the forefront of industry developments and deliver exceptional value to our customers.

Knowledge

We have developed extensive knowledge of seals and their applications, including their composition, lifetime and suitability for a specific job. The right choice of seal minimises the risk of unexpected breakdowns, so our team can advise on the best solution to save you from potential future issues.

We can make recommendations from our wide range of stocked seals or work with your specific requirements to design a bespoke sealing solution. Our team use their technical knowledge and experience to provide the best service to our customers.

We ensure high-quality sealing products through careful control and evaluation, and we are proud to have achieved several ISO certifications, including ISO9001:2015, ISO14001:2015, ISO45001:2018 and AS EN 9120:2018.

We also conform to many industry specific regulations, ensuring our sealing products comply to specific requirements and full traceability is maintained throughout the product lifecycle.

Quality Assurance



PTFE Sealing Systems

M Seals' program of PTFE seals consists of a variety of high-performance static and dynamic seals, designed for applications where high mechanic and chemical loads exceed the performance of traditional sealing materials.

PTFE seals are manufactured in processes that make the possible applications multiple, PTFE seals can be supplied according to standard programs, or adapted to existing housings, often without additional tooling cost.

PTFE seals are commonly used within chemical, food and drug, petrochemical, offshore and hydraulic industries.

CONCEPT

PTFE is a relatively inelastic material. To secure surface contact prior to system pressure, a PTFE seal must be equipped with an elastic element. This can be either a stainless steel spring (Fig.1) or an elastomer O-ring (Fig.2).

Each application determines whether one or the other is the most optimal type, often based upon working temperature or demand of chemical resistance.



Fig.1



Fig.2

MATERIALS

The basic material in these seals is PTFE, but in order to assure an optimal function, a variety of fillers like carbon, carbon-fibre, glass, bronze etc. can be added.

ADVANTAGES OF PTFE

- Resistant to a large number of chemicals and do not react with the fluid.
- Can be used within a wide temperature range, (-269° to +280°C) with considerations to the design.
- Good wear property and the elastic elements' low setting, secure a long service life.
- Has unlimited stock life, but considerations must be taken to lifetime of an eventual elastomer element.
- Has extremely low friction and does not bond to the contact surface.
- High resistance to extrusion.
- High surface speeds can be obtained up to 15m/s reciprocating and 4m/s for rotating.

TYPES











PTFE seals can be supplied as either single acting or double acting and can be adapted to AS568 O-ring grooves.

O-rings activated piston and rod seals acc. to ISO7425/1 and 7425/2.

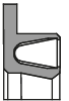

Range of Seals

STANDARD WORKING PARAMETERS















	PROFILE		APPLICATION			WORKING PARAMETERS			SPEED	
			Static	Dynamic	Rotary	Max. Pressure Dynamic Bar	Max. Pressure Static Bar	Temperature °C	Dynamic m/sec.	Rotary m/sec
M-FLEX	I90 	E90 	B	A	B	250	450	-70°C to +260°C	15	1
M-FLEX	I94 	E94 	A	B	B	250	450	-70°C to +260°C	10	0.5
M-FLEX	I99 		B	B	A	250	250	-70°C to +260°C	15	4
M-FLEX		I96 	E96 A	B	(B)	400	600	-200°C to +260°C	5	0.1
M-FLEX	F93 	F92 	A	C	C	400	600	-200°C to +260°C	-	-
M-FLEX	F90 	F91 	A	C	C	250	450	-70°C to +260°C	-	-

- A: Very Good
- B: Good
- C: Not recommended

Not all maximum characteristics can be obtained at the same time.

Range of Seals

STANDARD WORKING PARAMETERS

	PROFILE	APPLICATION			WORKING PARAMETERS			SPEED	
		Static	Dynamic	Rotary	Max. Pressure Dynamic Bar	Max. Pressure Static Bar	Temperature °C	Dynamic m/sec.	Rotary m/sec
M-GLIDE	D70  D80 	B	A	C	450	600	-54°C to +200°C	15	-
M-STEP	I70  E80 	B	A	(C)	450	600	-54°C to +200°C	15	0.1
M-TURN	D74  D84 	B	A	A	250	250	-54°C to +200°C	5	1
M-CAP	D78  D88 	B	A	C	250	250	-54°C to +200°C	5	-
M-GLIDE	D76  D86 	B	A	C	450	600	-54°C to +200°C	15	-
M-GLIDE	G10 G12 G14 G16 	A	A	B	-	-	-54°C to +200°C	15	0.1
M-WIPE	W54 	C	A	B	-	-	-54°C to +200°C	15	0.1
M-WIPE	W52 	C	A	B	-	-	-54°C to +200°C	15	0.1
M-WIPE	W50 	C	A	B	-	-	-54°C to +200°C	15	0.1

Note: Working temperature is depending on O-ring material.

A: Very Good
 B: Good
 C: Not recommended

Not all maximum characteristics can be obtained at the same time.



General Material Characteristics

MATERIAL CODE	CHARACTERISTIC	APPLICATION	TYPICAL PRODUCTS	RUNNING SURFACES
501 Virgin PTFE White	High chemical resistance Low friction Limited wear resistance	Chemical industry Food industry Pharmaceutical industry	Back-up rings Washers Spring activated seals	Aluminium Stainless steel Chromed steel Bronze
502 Virgin TFM White	High chemical resistance Low friction Limited wear resistance High mechanical strength	Chemical industry Food industry Pharmaceutical industry	Spring activated seals Valve seats	Aluminium Stainless steel Chromed steel Bronze
504 Modified PTFE Greenish/blueish	High chemical resistance Low friction Improved wear resistance	Chemical industry Light hydraulics	Spring activated seals O-ring activated seals	Hardened steel Chromed steel
510 PTFE/Car/Graphite Black	Good chemical resistance High mechanical strength Good wear resistance	Hydraulic industry Pneumatics Water/glycol solutions	O-ring activated seals Guide tape Spring activated seals	Hardened steel Chromed steel Stainless steel
511 PTFE/Carbon Black	Good chemical resistance Good mechanical strength Good wear resistance	General	Spring activated seals	Hardened steel Chromed steel Stainless steel
514 PTFE/Bronze Brownish	High mechanical strength High wear resistance	Hydraulic industry Hydraulic oils	O-ring activated seals Guide tape	Hardened steel Chromed steel Cast iron
518 PTFE/Econol Beige	Good mechanical strength Good wear resistance Non-wearing Low friction	Rotary applications	Spring activated seals O-ring activated seals	Aluminium Stainless steel
519 PTFE/Carbonfibre Greyish	High wear resistance High mechanical strength Good characteristic in water High chemical resistance	Water hydraulics Saltwater applications	Spring activated seals O-ring activated seals	Hardened steel Chromed steel Aluminium Ceramic coating Stainless steel
507 PTFE/Glass Grey/Green	High chemical resistance Good mechanical strength Good wear resistance High mechanical strength	Hydraulic industry	O-ring activated seals Guide tape	Hardened steel Chromed steel Cast iron
526 UHMW-PE White Max temp. +80°C	High wear resistance High mechanical strength Good characteristic in water Good dry running properties Good chemical resistance	Pneumatics Food industry Pharmaceutical industry	Spring activated seals O-ring activated seals Guide tape	Hardened steel Chromed steel Aluminium Ceramic coating Stainless steel
527 PUR57sh Transp. Yellow	Good mechanical strength Good wear resistance	Hydraulic industry	O-ring activated seals Wipers	Hardened steel Chromed steel Cast iron Ceramic coating Stainless steel

Other material compositions available on request.

Above mentioned working conditions are guidelines and it is the end user's responsibility to prove the product in the application.

M-FLEX

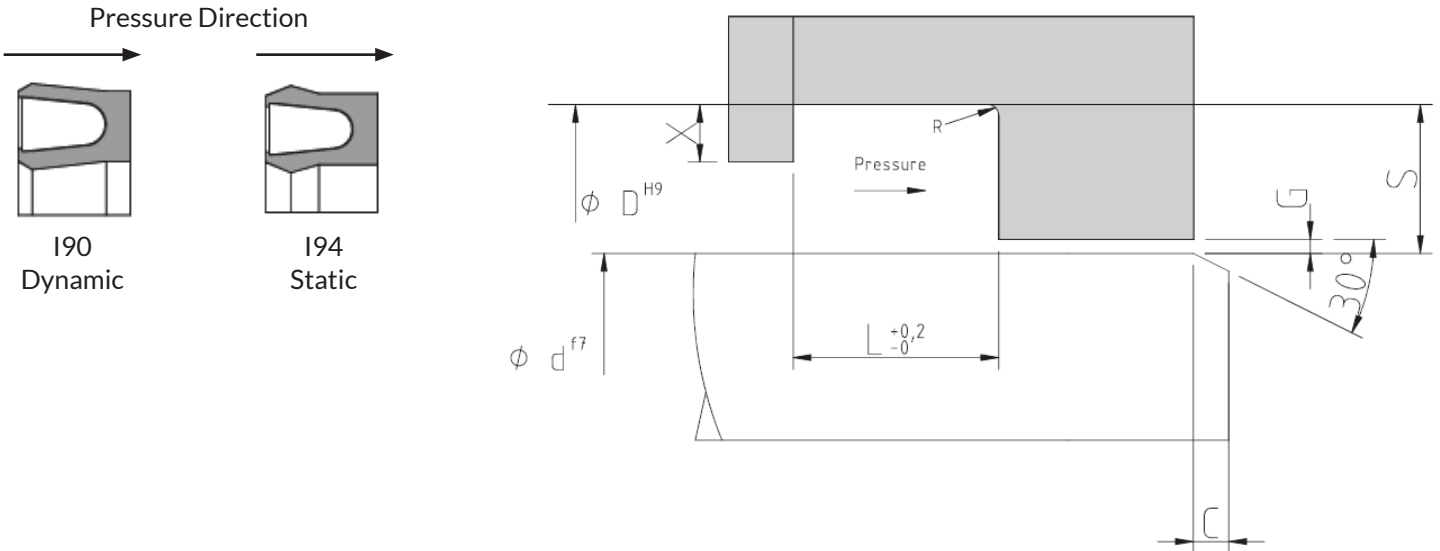

SECTION	HOUSING DIMENSION			D min.	C min.	X min.	R max.	G max.	Recommended Diameter Range
	S	L	L1						
A	1.45	2.40	3.80	3.00	2.00	0.50	0.40	0.065	3.00 - 9.99
B	2.25	3.60	4.65	8.00	2.20	0.60	0.40	0.065	10.00 - 19.99
C	3.10	4.80	5.70	12.00	2.40	0.70	0.60	0.075	20.00 - 39.99
D	4.70	7.10	8.50	20.00	3.80	0.90	0.80	0.085	40.00 - 119.99
E	6.10	9.50	11.20	35.00	5.50	0.90	0.80	0.125	120.00 - 629.99

Groove width L is standard. L1 is for seals with extended heal.

Assembly in split groove.

For assembly in semi open groove see p.22

Ordering Example;

I90 / 511 80.00 - 89.40 - 7.10 - S

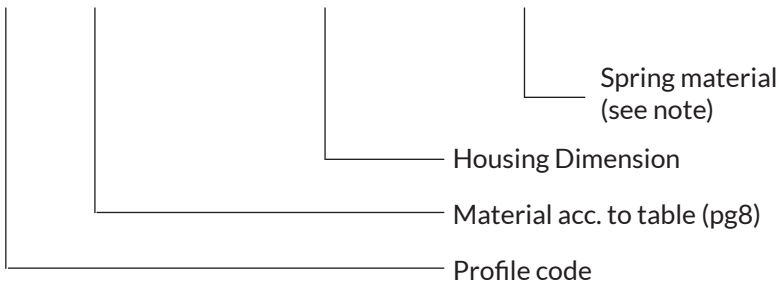

Note:

S for standard stainless steel spring

E for Elgiloy spring

H for Hasteloy (on request)



M-FLEX

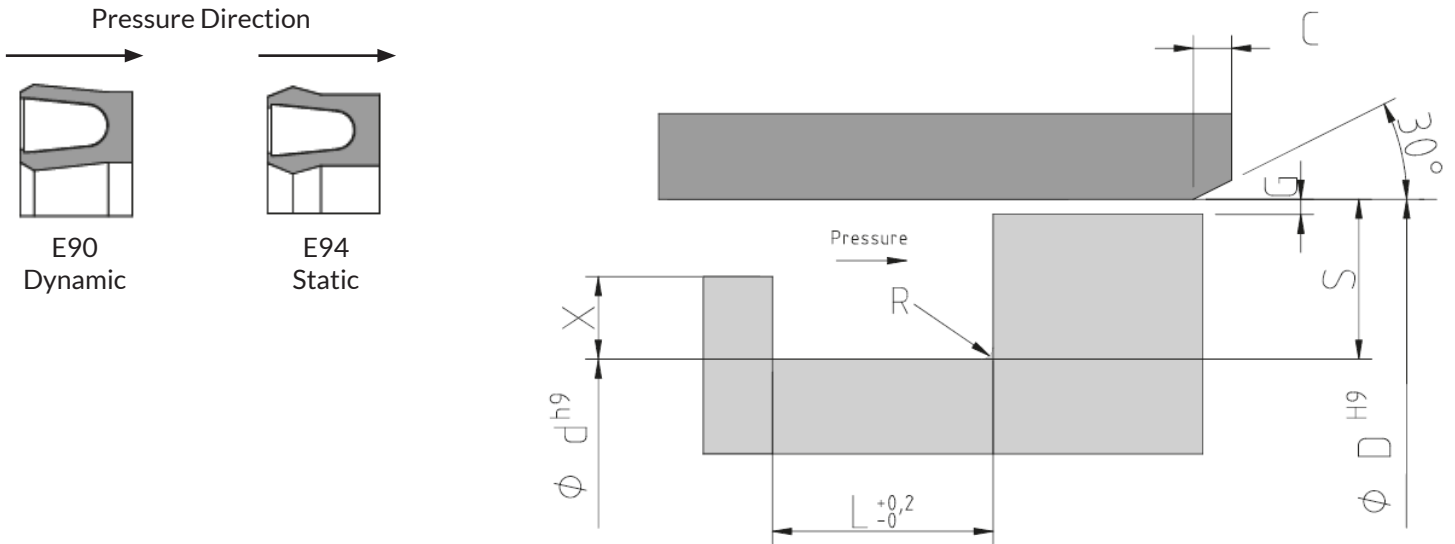

SECTION	HOUSING DIMENSION			D min.	C min.	X min.	R max.	G max.	Recommended Diameter Range
	S	L	L1						
A	1.45	2.40	3.80	6.00	2.00	0.50	0.40	0.065	6.00 - 13.99
B	2.25	3.60	4.65	13.00	2.20	0.60	0.40	0.065	14.00 - 24.99
C	3.10	4.80	5.70	18.00	2.40	0.70	0.60	0.075	25.00 - 45.99
D	4.70	7.10	8.50	28.00	3.80	0.90	0.80	0.085	46.00 - 124.99
E	6.10	9.50	11.20	45.00	5.50	0.90	0.80	0.125	125.00 - 629.99

Groove width L is standard. L1 is for seals with extended heal.

Assembly in split groove.

For assembly in semi open groove see p.22

Ordering Example;

E90 / 511 80.00 - 70.60 - 7.10 - S

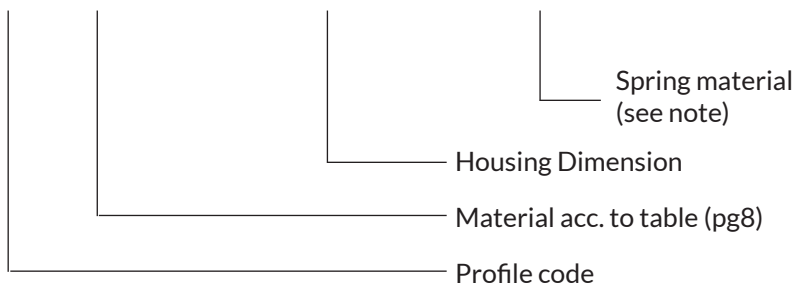

Note:

S for standard stainless steel spring

E for Elgiloy spring

H for Hasteloy (on request)

M-FLEX

Pressure Direction

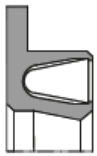

I99

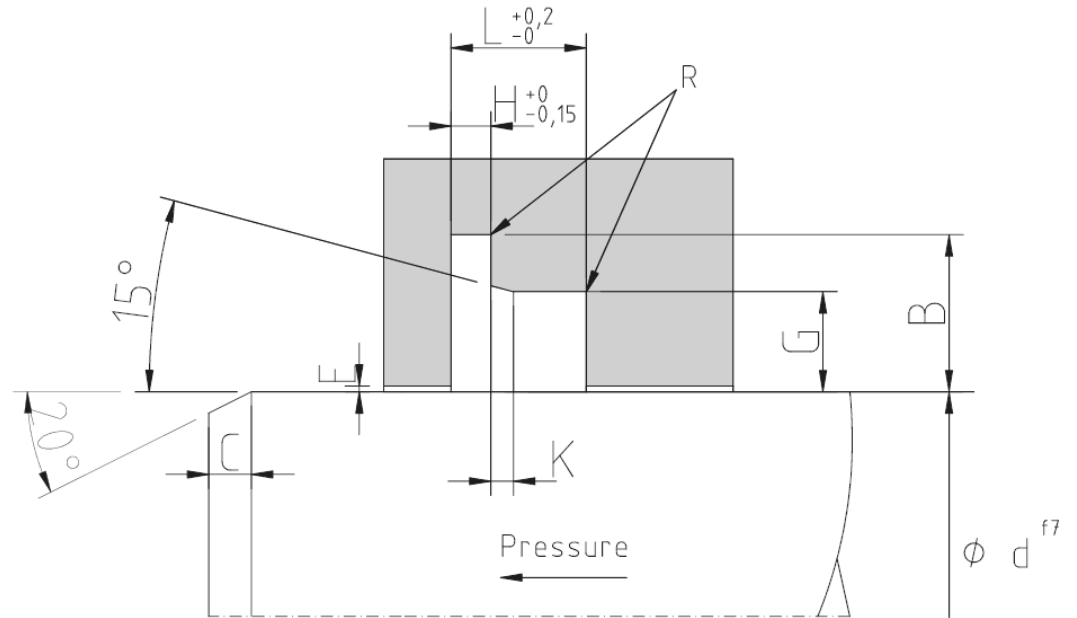

SECTION	HOUSING DIMENSION			D min.	C min.	B	R max.	E max.	K	Recommended Diameter Range
	G	L	H							
B	2.50	3.60	0.85	8.00	2.20	4.50	0.30	0.13	0.80	8.00 - 19.99
C	3.50	4.80	1.35	12.00	2.40	6.25	0.40	0.13	1.10	20.00 - 39.99
D	5.25	7.10	1.80	20.00	3.80	8.75	0.50	0.15	1.40	40.00 - 119.99
E	7.00	9.50	2.80	35.00	5.50	11.00	0.50	0.17	1.60	120.00 -

Assembly in split groove.

Ordering Example;

I99 / 511 80.00 - 90.50 - 7.10 - S

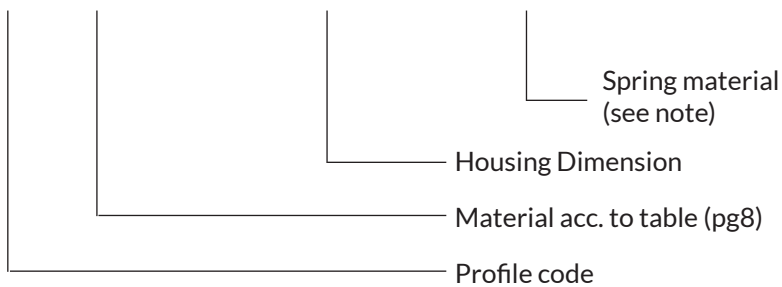

Note:
S for standard stainless steel spring
E for Elgiloy spring
H for Hasteloy (on request)



M-FLEX

Pressure Direction

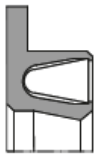

I96

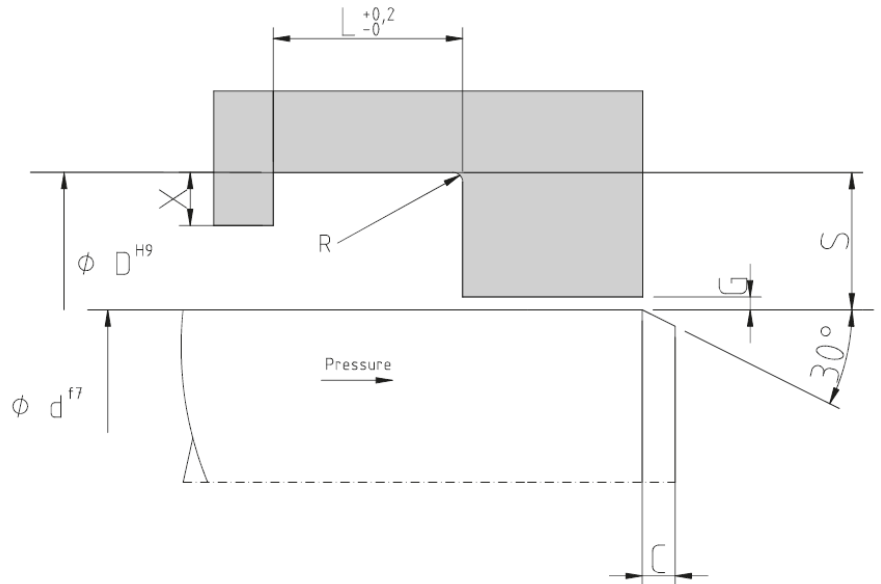

SECTION	HOUSING DIMENSION			D min.	C min.	X min.	R max.	G max.	Recommended Diameter Range
	S	L	L1						
A	1.45	2.40	3.80	3.00	2.00	0.50	0.40	0.065	3.00 - 9.99
B	2.25	3.60	4.65	10.00	2.20	0.60	0.40	0.065	10.00 - 19.99
C	3.10	4.80	5.70	20.00	2.40	0.70	0.60	0.075	20.00 - 39.99
D	4.70	7.10	8.50	40.00	3.80	0.90	0.80	0.085	40.00 - 119.99
E	6.10	9.50	11.20	120.00	5.50	0.90	0.80	0.125	120.00 - 629.99

Groove width L is standard. L1 is for seals with extended heal.

Assembly in split groove.

For assembly in semi open groove see p.22

Ordering Example;

I96 / 511 80.00 - 89.40 - 7.10 - S

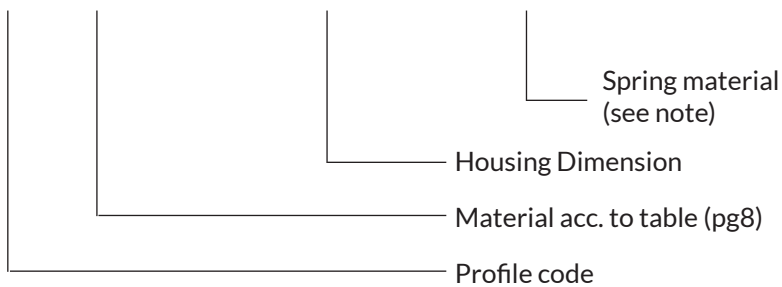

Note:

S for standard stainless steel spring

E for Elgiloy spring

H for Hasteloy (on request)

M-FLEX

Pressure Direction

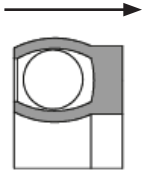

E96

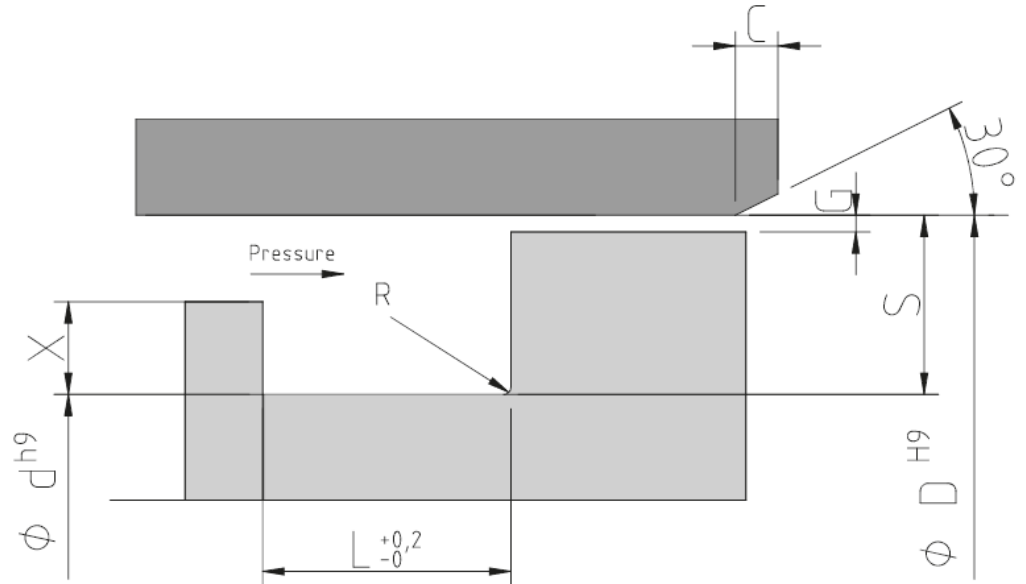

SECTION	HOUSING DIMENSION			D min.	C min.	X min.	R max.	G max.	Recommended Diameter Range
	S	L	L1						
A	1.45	2.40	3.80	6.00	2.00	0.50	0.40	0.065	6.00 - 13.99
B	2.25	3.60	4.65	14.00	2.20	0.60	0.40	0.065	14.00 - 24.99
C	3.10	4.80	5.70	25.00	2.40	0.70	0.60	0.075	25.00 - 45.99
D	4.70	7.10	8.50	46.00	3.80	0.90	0.80	0.085	46.00 - 124.99
E	6.10	9.50	11.20	125.00	5.50	0.90	0.80	0.125	125.00 - 629.99

Groove width L is standard. L1 is for seals with extended heal.

Assembly in split groove.

For assembly in semi open groove see p.22

Ordering Example;

E96 / 511 80.00 - 70.60 - 7.10 - S

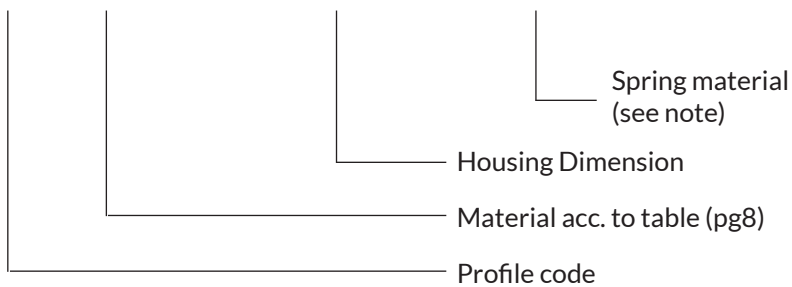

Note:

S for standard stainless steel spring

E for Elgiloy spring

H for Hasteloy (on request)



M-FLEX

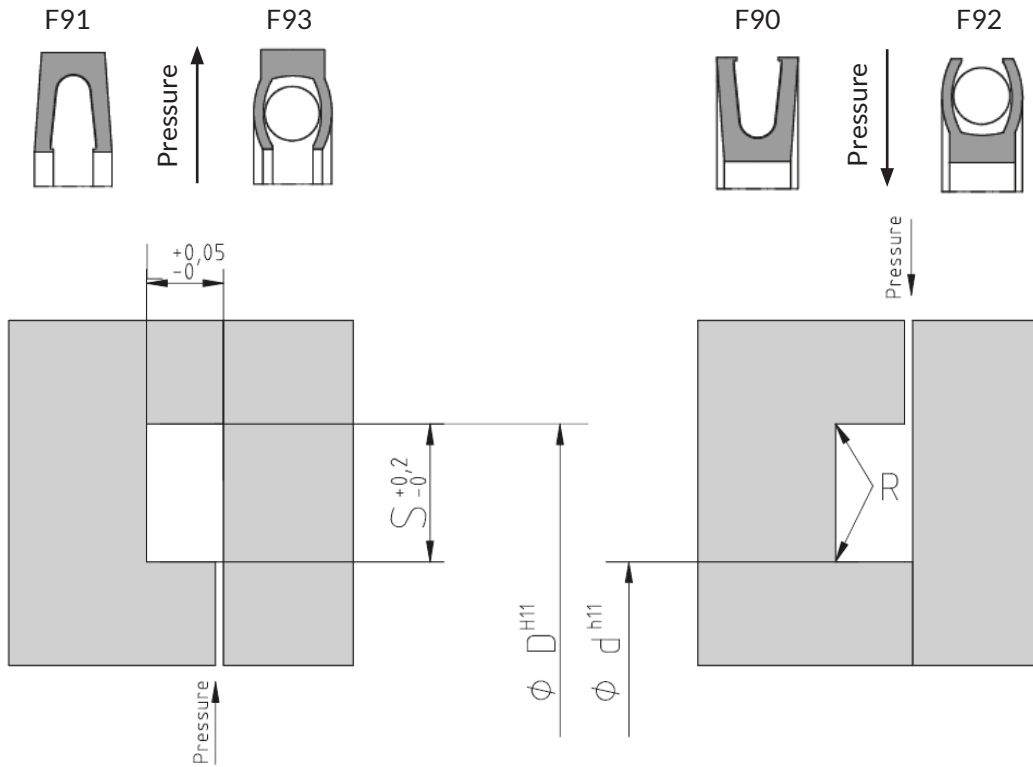

SECTION	HOUSING DIMENSION		F90 d min.	F91 D min.	F92 d min.	F93 D min.	R max.
	S	L					
A	2.4	1.45			5.00	12.00	0.40
B	3.6	2.25	40.00	32.00	10.00	20.00	0.40
C	4.8	3.10	45.00	45.00	15.00	30.00	0.60
D	7.1	4.70	80.00	80.00	22.00	40.00	0.80
E	9.5	6.10	110.00	110.00	30.00	50.00	0.80

Ordering Example;

F93 / 511 80.00 - 94.20 - 4.70 - S

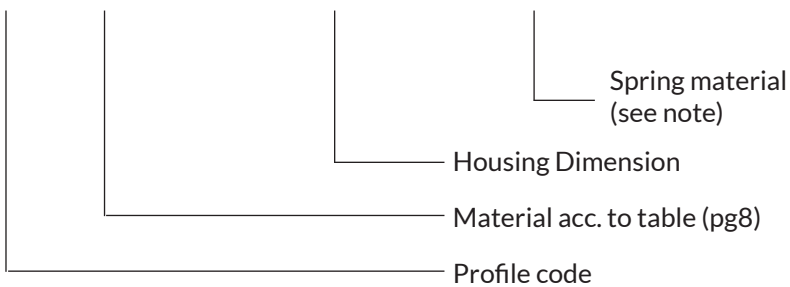

Note:
 S for standard stainless steel spring
 E for Elgiloy spring
 H for Hasteloy (on request)



M-STEP/M-GLIDE

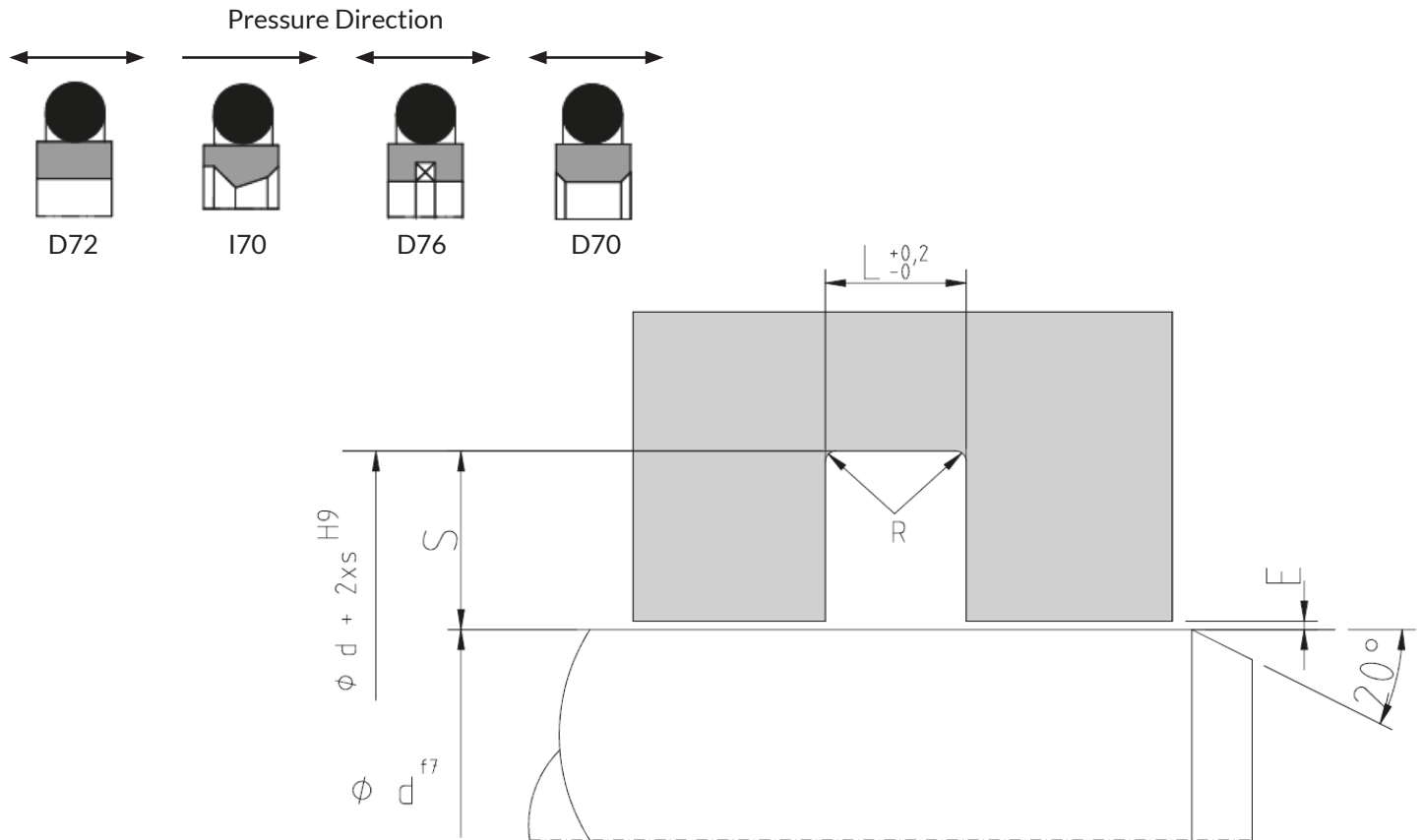

SECTION	Ød	S	L	MAXIMUM GAP E		O-Ring	R max.
				0-200 bar	200-400 bar		
A	4 - 7.9	2.45	2.20	0.40	0.20	1.78	0.4
B	8 - 18.9	3.75	3.20	0.50	0.30	2.62	0.6
C	19 - 37.9	5.50	4.20	0.50	0.30	3.53	0.8
D	38 - 199.9	7.75	6.30	0.60	0.40	5.33	1.3
E	200 - 255.9	10.50	8.10	0.70	0.50	6.99	1.5
F	256 - 649.9	12.25	8.10	0.70	0.50	6.99	1.5

Ø d is the recommended standard diameter range.

Any section can be ordered different from the standard diameter range.

Ordering Example;

D70 / 514 80.00 - 95.50 - 6.30

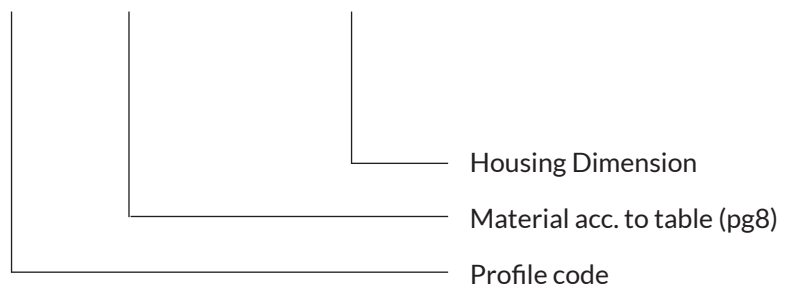

M-STEP/M-GLIDE

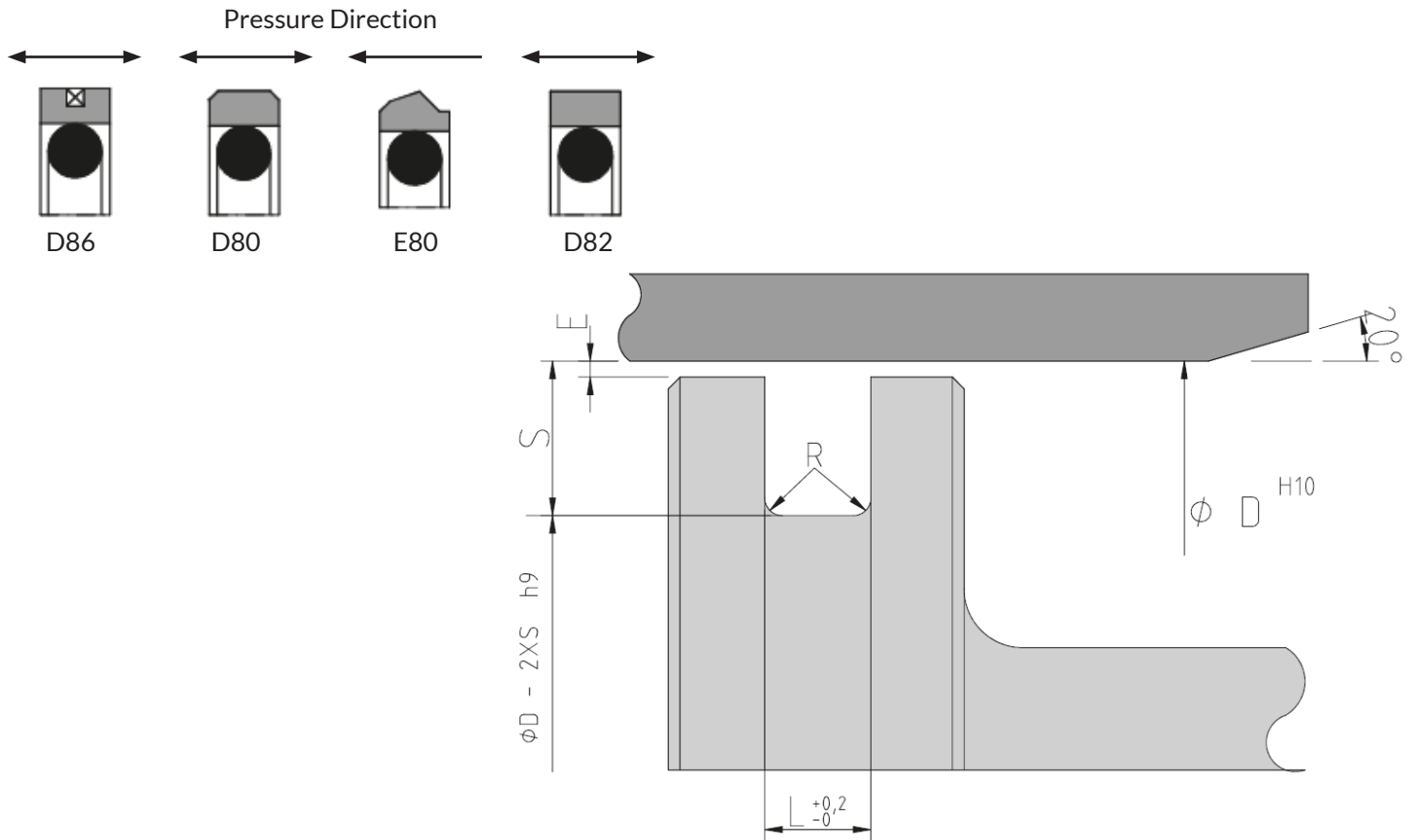

SECTION	Ø d	S	L	MAXIMUM GAP E		O-Ring	R max.
				0-200 bar	200-400 bar		
A	8 - 14.9	2.45	2.20	0.40	0.20	1.78	0.4
B	15 - 39.9	3.75	3.20	0.50	0.30	2.62	0.6
C	40 - 79.9	5.50	4.20	0.50	0.30	3.53	0.8
D	80 - 132.9	7.75	6.30	0.60	0.40	5.33	1.3
E	133 - 329.9	10.50	8.10	0.70	0.50	6.99	1.5
F	330 - 669.9	12.25	8.10	0.70	0.50	6.99	1.5

Ø d is the recommended standard diameter range.

Any section can be ordered different from the standard diameter range.

Ordering Example;

D80 / 514 80.00 - 64.50 - 6.30

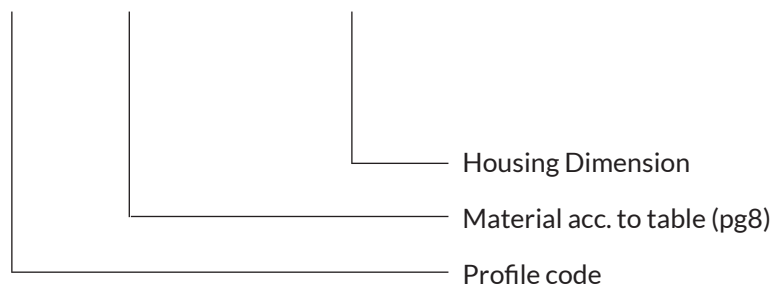

M-TURN

Double acting seal for slow turning applications such as swivel joints, rotary distributors etc.

Velocity: up to 1 m/sec

$P \times V < 40$ (Pressure x Velocity)

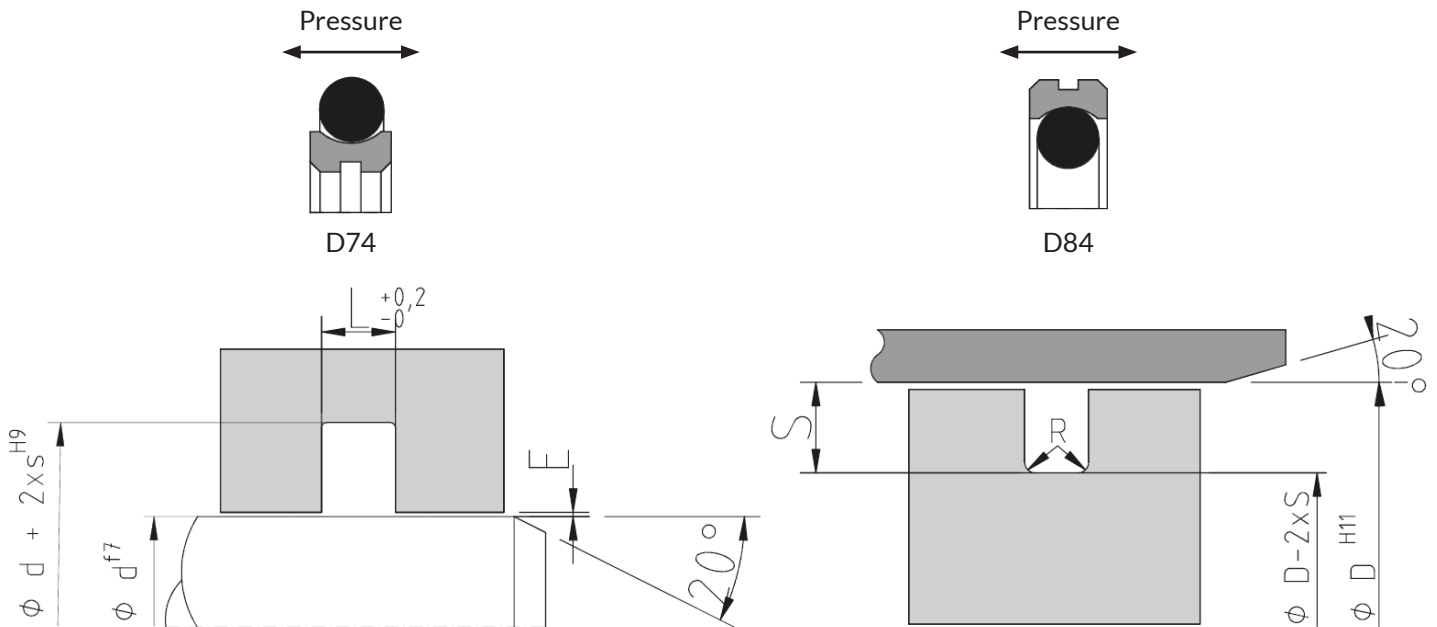
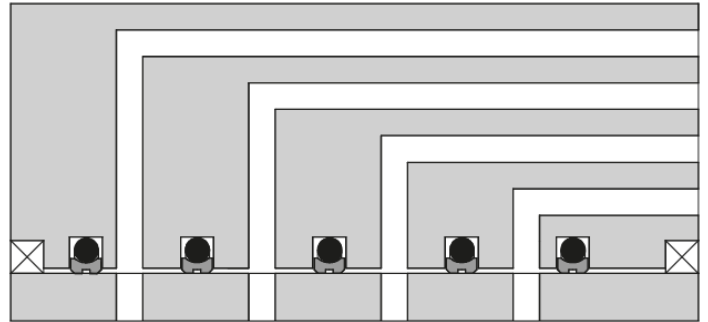

SECTION	ϕd (TYPE D74)	ϕd (TYPE D84)	S	L	MAXIMUM GAP E		O-Ring	R max.
					0-200 bar	200-400 bar		
A	6 - 18.9	8 - 39.9	2.45	2.20	0.40	0.20	1.78	0.4
B	19 - 37.9	40 - 79.9	3.75	3.20	0.50	0.30	2.62	0.6
C	38 - 199.9	80 - 132.9	5.50	4.20	0.50	0.30	3.53	0.8
D	200 - 255.9	133 - 329.9	7.75	6.30	0.60	0.40	5.33	1.3
E	256 - 649.9	330 - 669.9	10.50	8.10	0.70	0.50	6.99	1.5
F	650 - 999.9	670 - 999.9	12.25	8.10	0.70	0.50	6.99	1.5

ϕd is the recommended standard diameter range.

Any section can be ordered different from the standard diameter range.

D84 is not recommended for new design.

Ordering Example;

D74 / 510 40.00 - 51.00 - 4.20

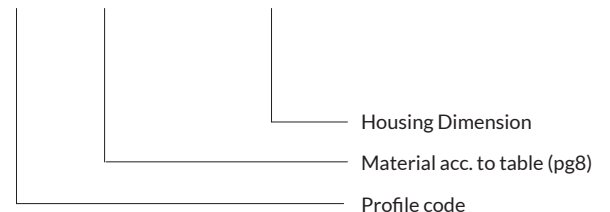

M-CAP

Pressure

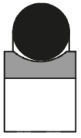

D78

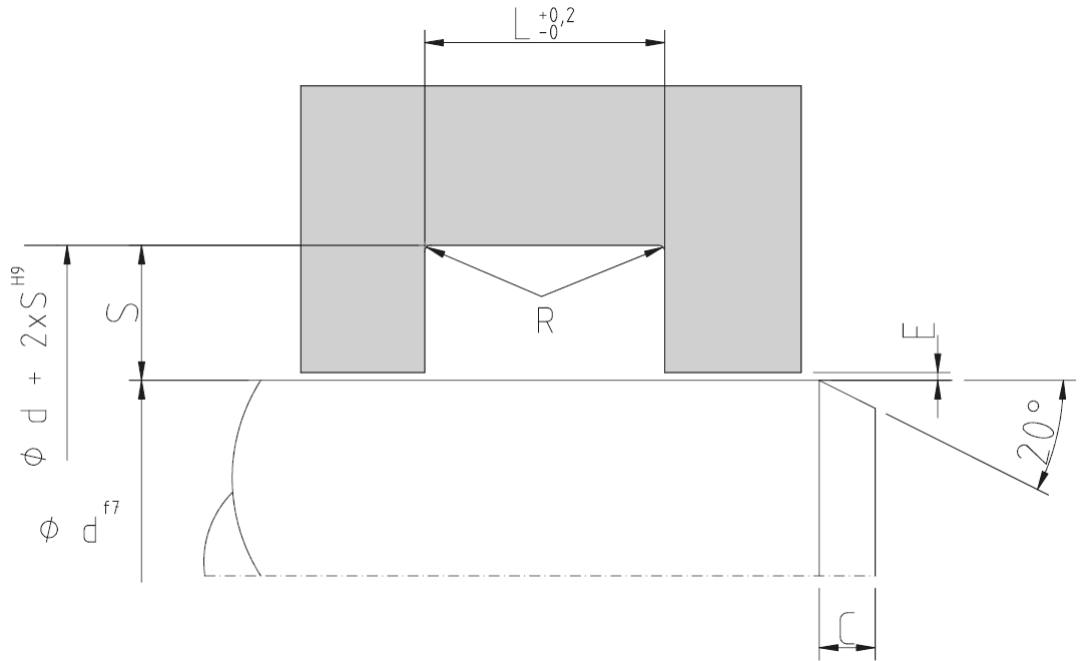

SECTION	ϕd	S	L	L1	L2	O-Ring	R max.	E max.	C
A	4 - 9.9	1.45	2.40	3.80	5.30	1.78	0.4	0.08	2.50
B	10 - 19.9	2.25	3.60	4.60	6.20	2.62	0.5	0.10	2.70
C	20 - 39.9	3.10	4.80	5.70	7.70	3.53	0.6	0.12	2.90
D	40 - 119.9	4.70	7.10	8.50	10.80	5.33	0.7	0.15	4.30
E	120 - 400.9	6.10	9.50	11.20	14.70	6.99	0.8	0.15	6.00
F	4 - 19.9	2.00	3.20	4.60	6.00	2.40	0.5	0.08	2.70
K	20 - 45.9	2.50	4.00	5.40	6.80	3.00	1.0	0.10	2.90
L	46 - 145.9	5.00	7.50	9.30	11.10	5.70	1.0	0.12	4.50
M	146 - 250.9	7.50	11.00	13.20	15.40	8.40	1.0	0.15	7.00

ϕd is the recommended standard diameter range.

Any section can be ordered different from the standard diameter range.

Groove width L is standard.

L1 is for existing O-ring groove with 1 back-up ring.

L2 is for existing O-ring groove with 2 back-up rings.

Ordering Example;

D78 / 501 80.00 - 89.40 - 7.10

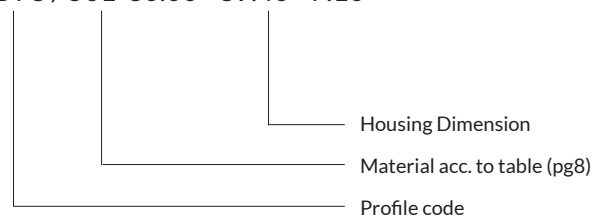

M-CAP

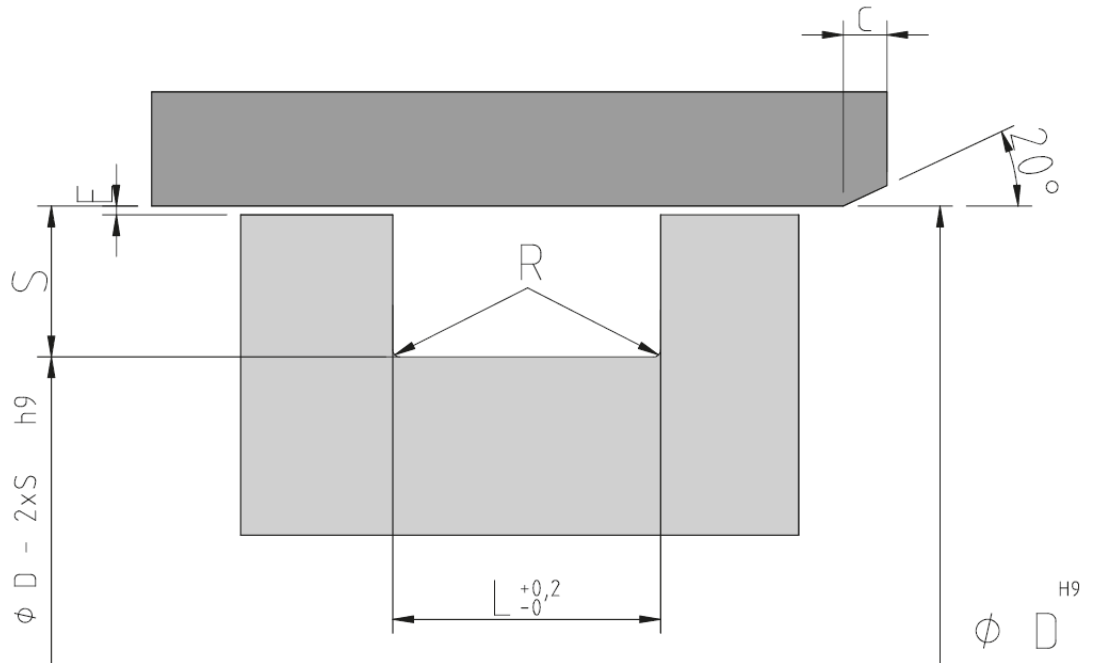
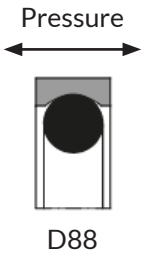

SECTION	Ø d	S	L	L1	L2	O-Ring	R max.	E	C
A	8 - 13.9	1.45	2.40	3.80	5.30	1.78	0.4	0.08	2.50
B	14 - 24.9	2.25	3.60	4.60	6.20	2.62	0.5	0.10	2.70
C	25 - 45.9	3.10	4.80	5.70	7.70	3.53	0.6	0.12	2.90
D	46 - 124.9	4.70	7.10	8.50	10.80	5.33	0.7	0.15	4.30
E	125 - 400.9	6.10	9.50	11.20	14.70	6.99	0.8	0.15	6.00
F	8 - 24.9	2.00	3.20	4.60	6.00	2.40	0.5	0.08	2.70
K	25 - 54.9	2.50	4.00	5.40	6.80	3.00	1.0	0.10	2.90
L	55 - 159.9	5.00	7.50	9.30	11.10	5.70	1.0	0.12	4.50
M	160 - 265.9	7.50	11.00	13.20	15.40	8.40	1.0	0.15	7.00

Ø d is the recommended standard diameter range.

Any section can be ordered different from the standard diameter range.

Groove width L is standard.

L1 is for existing O-ring groove with 1 back-up ring.

L2 is for existing O-ring groove with 2 back-up rings.

Ordering Example;
D88 / 501 80.00 - 70.60 - 7.10

Housing Dimension
 Material acc. to table (pg8)
 Profile code



M-GLIDE

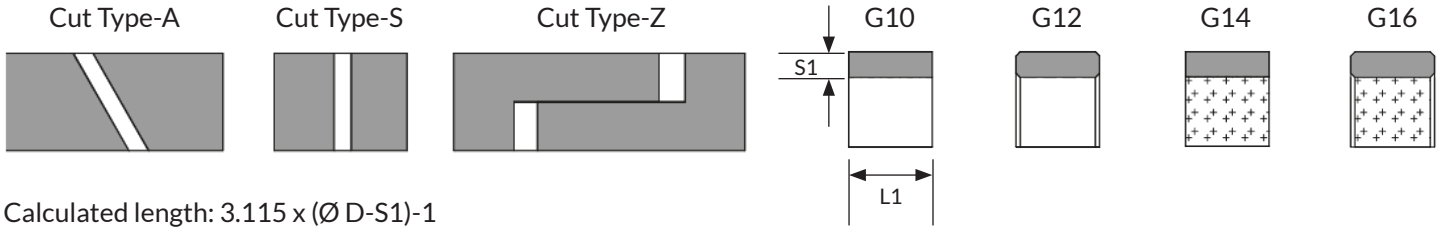

Calculated length: $3.115 \times (\text{Ø D} - \text{S1}) - 1$

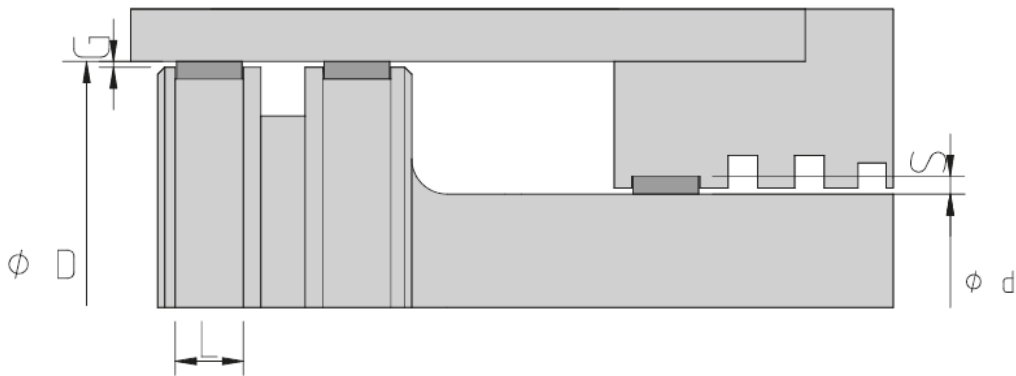

Size	S	L	S1	L1	Ø D H10	Ø d h9	R max.	G
15-032	1.5	3.2	1.5	3.0	Ød + 3	Ød - 3	0.3	See gap for corresponding seal
15-063	1.5	6.3	1.5	6.1	Ød + 3	Ød + 3	0.3	
16-025	1.55	2.5	1.55	2.4	Ød + 3.1	Ød + 3.1	0.3	
16-040	1.55	4.0	1.55	3.9	Ød + 3.1	Ød + 3.1	0.3	
20-042	2.0	4.2	2.0	4.0	Ød + 4.0	Ød + 4.0	0.3	
20-063	2.0	6.3	2.0	6.1	Ød + 4.0	Ød + 4.0	0.3	
20-081	2.0	8.1	2.0	7.9	Ød + 4.0	Ød + 4.0	0.3	
20-097	2.0	9.7	2.0	9.5	Ød + 4.0	Ød + 4.0	0.3	
20-150	2.0	15.0	2.0	14.8	Ød + 4.0	Ød + 4.0	0.3	
25-042	2.5	4.2	2.5	4.0	Ød + 5.0	Ød + 5.0	0.3	
25-056	2.5	5.5	2.5	6.1	Ød + 5.0	Ød + 5.0	0.3	
25-063	2.5	6.3	2.5	6.1	Ød + 5.0	Ød + 5.0	0.3	
25-081	2.5	8.1	2.5	7.9	Ød + 5.0	Ød + 5.0	0.3	
25-097	2.5	9.7	2.5	9.5	Ød + 5.0	Ød + 5.0	0.3	
25-150	2.5	15.0	2.5	14.8	Ød + 5.0	Ød + 5.0	0.3	
25-200	2.5	20.0	2.5	19.5	Ød + 5.0	Ød + 5.0	0.3	
25-250	2.5	25.0	2.5	24.5	Ød + 5.0	Ød + 5.0	0.3	
25-300	2.5	30.0	2.5	29.5	Ød + 5.0	Ød + 5.0	0.3	

Other sizes are available on request.

Ordering Example;
G10 / 514 80.00 - 85.00 - 9.7-A

- Groove dimension + cut type
- Material acc. to table (pg8)
- Profile code

Ordering Example;
G10 / 514 25-097

- Groove dimension
- Material acc. to table (pg8)
- Profile code



M-WIPE

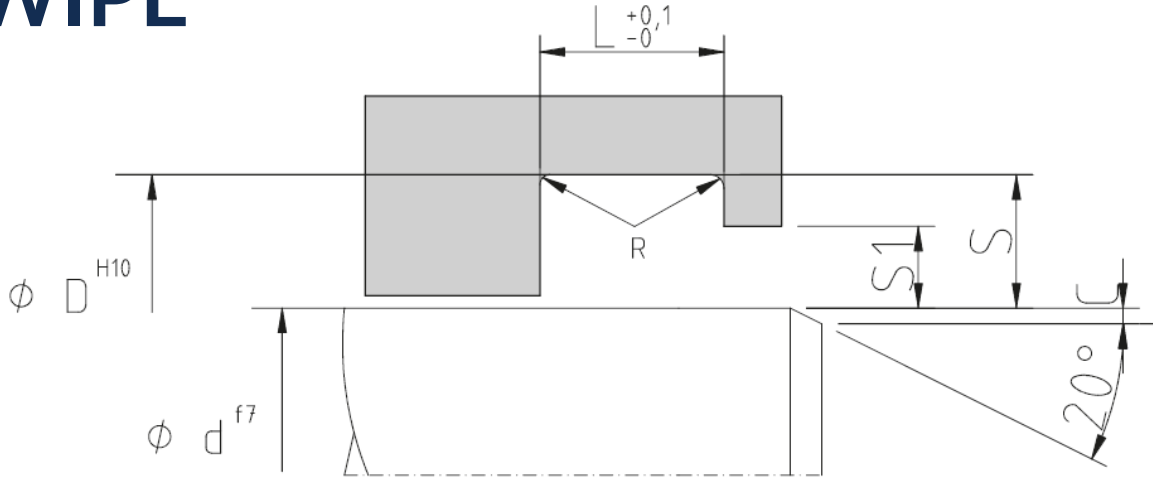

W54

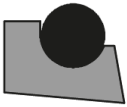

SECTION	HOUSING DIMENSION			d min.	Ø D	C min.	R max.	O-Ring
	S	L	S1					
A	2.40	3.70	1.35	6.00	Ød + 4.80	0.75	0.40	1.78
B	3.40	5.00	1.75	12.00	Ød + 6.80	1.00	0.40	2.62
C	4.40	6.00	2.00	65.00	Ød + 8.80	1.30	0.60	3.53
D	6.10	8.40	2.25	250.00	Ød + 12.20	2.00	0.80	5.33
E	8.00	11.00	2.60	420.00	Ød + 16.00	2.50	1.00	7.00
	10.00	14.00	3.30	650.00	Ød + 20.00	2.80	1.30	8.40

W52



SECTION	HOUSING DIMENSION			d min.	Ø D	C min.	R max.	O-Ring
	S	L	S1					
A	2.40	3.70	0.75	6.00	Ød + 4.80	0.75	0.40	1.78
B	3.40	5.00	0.75	12.00	Ød + 6.80	1.00	0.40	2.62
C	4.40	6.00	1.00	65.00	Ød + 8.80	1.30	0.60	3.53
D	6.10	8.40	1.00	250.00	Ød + 12.20	2.00	0.80	5.33
E	8.00	11.00	1.25	420.00	Ød + 16.00	2.50	1.00	7.00
	10.00	14.00	1.25	650.00	Ød + 20.00	2.80	1.30	8.40

W50



SECTION	HOUSING DIMENSION			d min.	Ø D	C min.	R max.	O-Ring
	S	L	S1					
A	3.80	4.20	0.50	8.00	Ød + 7.60	1.00	0.40	2.62
B	4.40	6.30	0.75	40.00	Ød + 8.80	1.00	0.40	2.62
C	6.10	8.10	1.00	70.00	Ød + 12.20	1.30	0.60	3.53
D	8.00	9.50	1.25	140.00	Ød + 16.00	2.00	0.80	5.33
E	12.00	14.00	1.25	400.00	Ød + 12.00	2.50	1.00	7.00
	14.00	16.00	1.75	650.00	Ød + 28.00	2.80	1.30	8.40

Ø d is the recommended standard diameter range.

Any section can be ordered different from the standard diameter range.

Ordering Example;

W52 / 514 80.00 - 88.80 - 6.00

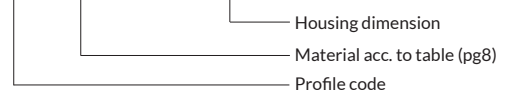

M-FLEX GROOVE DIMENSION

Snap-in Design

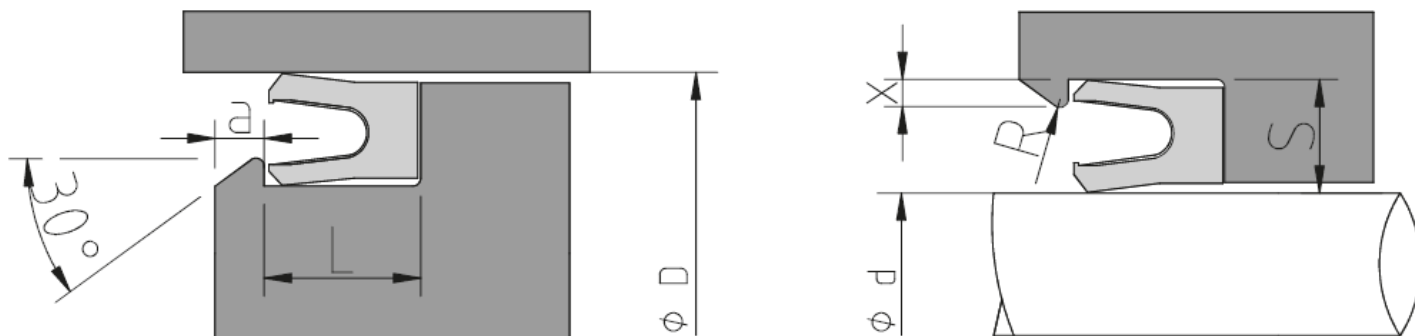

Profile	GROOVE DIMENSION		Ø d min.	Ø D min,	X +0.1	R	a
	S	L					
A	1.45	2.20	12.00	15.00	0.50	0.40	2.00
B	2.25	3.60	20.00	21.00	0.60	0.40	2.00
C	3.10	4.80	30.00	25.00	0.70	0.60	2.50
D	4.70	7.10	40.00	30.00	0.90	0.80	3.00
E	6.10	9.50	60.00	50.00	0.90	0.80	3.00

SURFACE FINISHES

Recommended surface finish for dynamic and static surfaces:

MEDIA	STATIC	DYNAMIC	ROTARY
Low molecular gases and fluids Fluids with low surface tension Low temperature	$Ra \leq 0.3$ $Rt \leq 1.2$	$Ra \leq 0.2$ $Rt \leq 0.8$	$Ra \leq 0.1$ $Rt \leq 0.4$
Low viscosity fluids High molecular gases Air and natural gas	$Ra \leq 0.6$ $Rt \leq 2.4$	$Ra \leq 0.3$ $Rt \leq 1.2$	$Ra \leq 0.2$ $Rt \leq 0.8$
Normal and high viscosity fluids Water, oils and phosphate esters	$Ra \leq 0.8$ $Rt \leq 3.2$	$Ra \leq 0.4$ $Rt \leq 1.6$	$Ra \leq 0.2$ $Rt \leq 0.8$

Surface roughness for static surfaces on O-ring activated seals

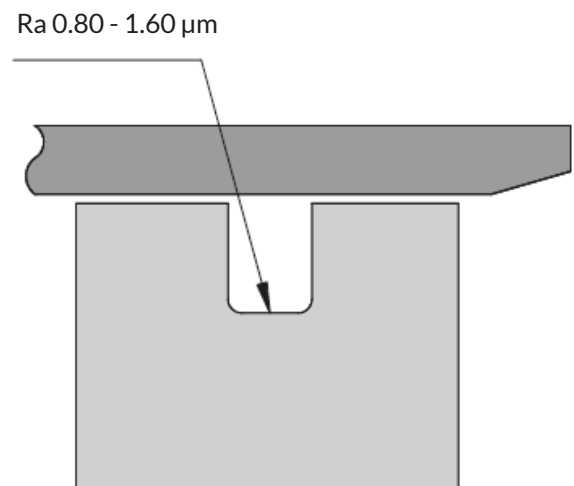
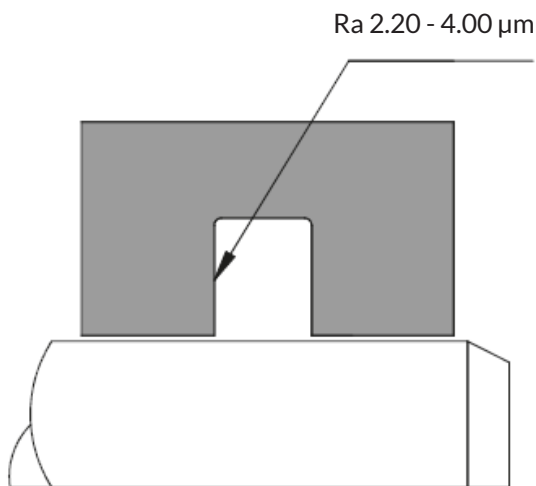

O-RING INSIDE DIAMETER

TYPE: D80 / D82 / D84 / D88 / E80

Nominal $\varnothing d$ +3% / -5%

TYPE: D78

Nominal $\varnothing d + 1\text{mm}$ +3% / -5%

TYPE: D70 / D72 / D74 / I70

Section A: $\varnothing d + 2.0\text{mm}$ +3% / -5%

Section B: $\varnothing d + 3.4\text{mm}$ +3% / -5%

Section C: $\varnothing d + 5.1\text{mm}$ +3% / -5%

Section D: $\varnothing d + 6.9\text{mm}$ +3% / -5%

Section E: $\varnothing d + 9.5\text{mm}$ +3% / -5%

Section F: $\varnothing d + 13\text{mm}$ +3% / -5%

TYPE: W50 / W52 / W54

Section A: $\varnothing d + 2.0\text{mm}$ +3% / -5%

Section B: $\varnothing d + 3.5\text{mm}$ +3% / -5%

Section C: $\varnothing d + 4.0\text{mm}$ +3% / -5%

Section D: $\varnothing d + 5.0\text{mm}$ +3% / -5%

Section E: $\varnothing d + 6.0\text{mm}$ +3% / -5%

Working temperature with NBR: -30°C to +100°C

Working temperature with FPM: -20°C to +200°C

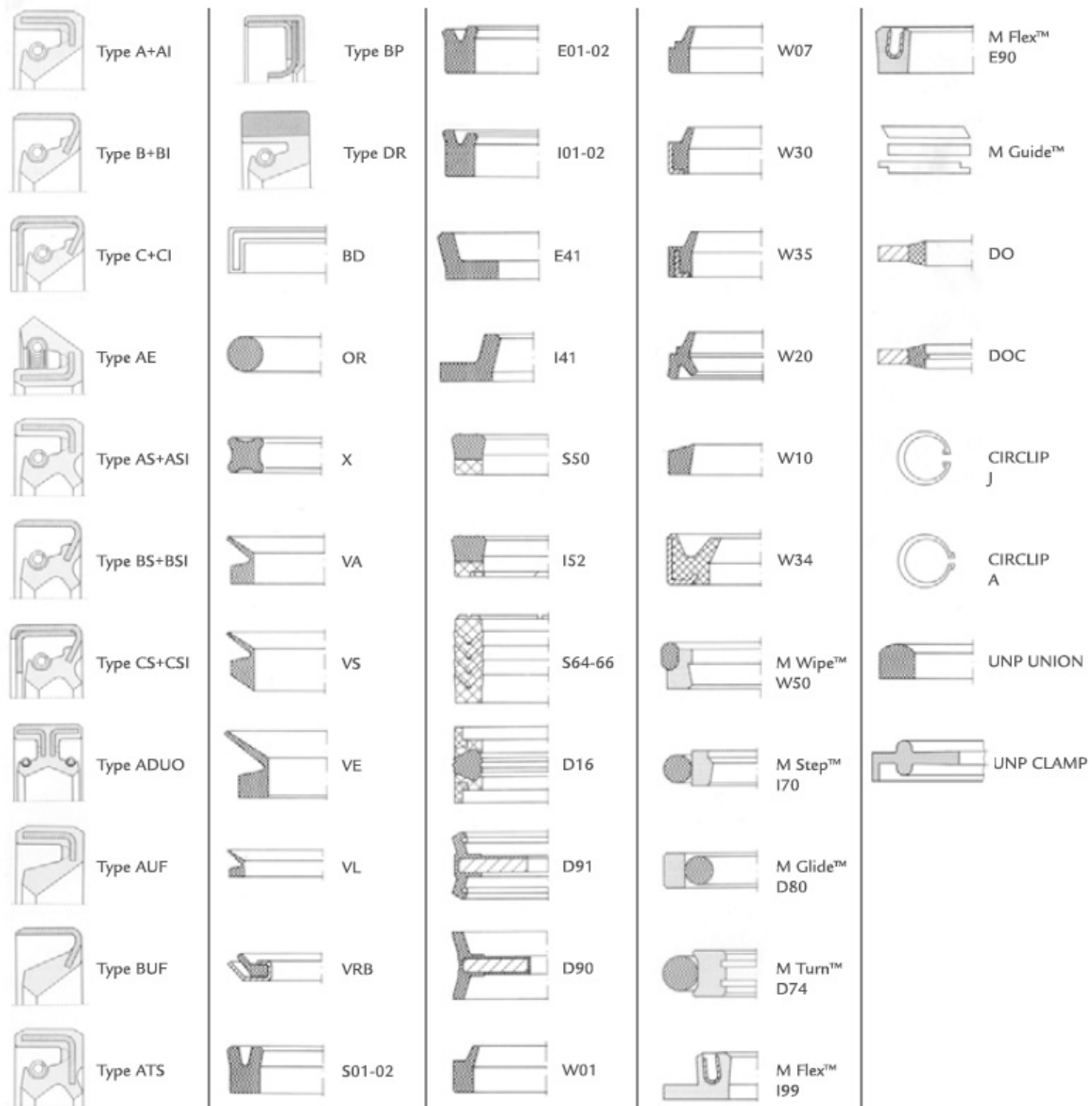

Small things make **GREAT** things possible